

## Removable Deformometer 200

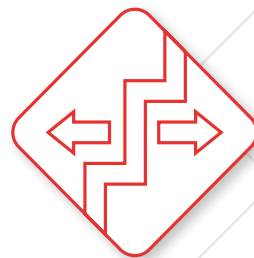

[www.pizzi-instruments.it](http://www.pizzi-instruments.it)

Instruments and Systems for Geotechnical and Structural Monitoring

## Removable Deformometer 200



### Description

Pizzi Instruments' removable deformometer 200 is a portable mechanical crackmeter with a base of 200 mm used for the control and measurement of the behavior of small cracks and fractures or the movement of structural joints.

It is made either of a stainless steel or Invar body, complete and with tapered reference tips for measurement and an indicator dial, either analog or digital. The accuracy of the instrument is centesimal for the stainless model and millesimal for the invar model. The standard base size is 200mm and the measuring range is 5 mm.

The measuring points are equipped with small circular seats positioned either side of the fissure into which the tips of deformometer are inserted during the survey.

Its main advantages are:

- **non-invasiveness**
- **ease of handling and simplicity of installation and reading**
- **speed of execution**

Special design features make the instrument sturdy and totally protected from humidity and other weather conditions often found in environments subject to monitoring. The instrument comes with a calibrated control template (stainless steel or Invar), for verification and periodic calibration of the instrument and a shockproof carrying case.

Important feature of all our deformometers and crackmeters, as well as many of our other instruments, is total compatibility with products manufactured and developed by the Officine Galileo of Florence.

### Application

Structural and geotechnical monitoring; monitoring of cracks and surface deformations; integration with automatic measurements from electrical or vibrating wire crackmeters.

The deformometer is used for control and monitoring of:

- **Housing**
- **Historical buildings**

- Dams
- Monuments
- Bridges
- Tunnels
- Other

### Features and benefits

The most important advantages in the use of our removable deformometer 200 are:

- Great accuracy
- High reliability
- Small footprint
- Good handling
- Ability to carry out controls in several places in a very short time
- Media compatibility with products developed by Officine Galileo of Florence

### Measuring principle

Made of a rigid stainless steel or Invar bar, at one end is a fixed reference tip; at the other end, a second pivoted reference tip, free to rotate by a small angle equal to the measuring range of the instrument.

The movable tip hinge is made of a bearing in the stainless steel centesimal model and special blades rectified in the Invar millesimal model.

When measuring, the two conical tips are placed on two specific circular housings fixed to the wall, straddling the crack or joint or base of the deformation being measured. An accurate system of levers transduces the distance between the two reference tips on an analog or digital comparator.

Our gauges are supplied with a precision template for testing and periodic calibration of the instrument. The round mountings provided for straddling the crack are special cylindrical tablets, with a calibrated hole to accommodate the tips.

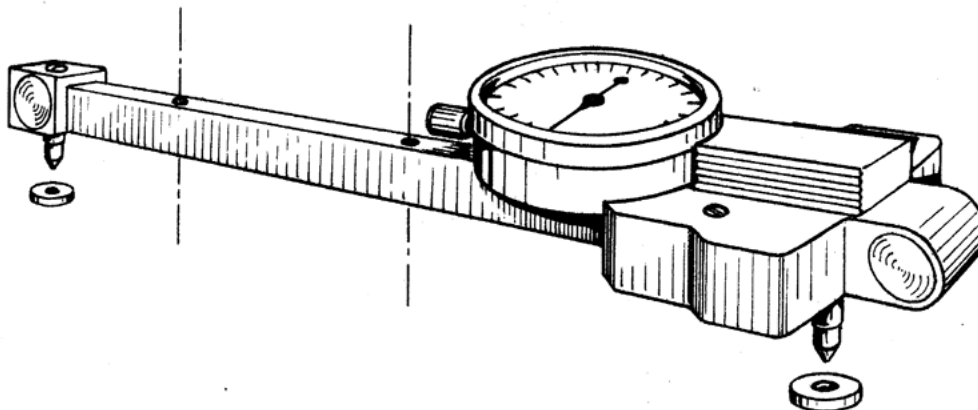

### Technical specifications

Product code	CRC2002001	CRC2101001	CRC2201001	CRC2301001
Type	Stainless steel – Analogue	Stainless Steel – Digital	Invar Analogue	Invar Digital
Material	Stainless steel	Stainless Steel	Invar	Invar
Dial Gauge	Analogue	Digital	Analogue	Digital
Measuring Base	200 mm	200 mm	200 mm	200 mm
Range	5 mm	5 mm	5 mm	5 mm
Sensitivity	0,01 mm	0,01 mm	0,001 mm	0,001 mm

For specific needs and requests, we are able to design and manufacture customized products different from standard.

### Accessories and spare parts

Control Template	CRC8003001
Fixing Template for measuring tablets	CRC8003002
Tablets	CRC80020xx
Frame for deformometer 200	CRC8003003
Analogue Dial Gauge/td>	CRC1001030
Digital Dial Gauge	CRC1001031

### Related products

Removable Deformometer 700	CRC7001001 - CRC7101001
Vibrating Wire Crackmeter	CRC6002xxx ( xxx=campo in mm)
Mechanical Deformometer 3D	CRC5102103
Vibrating Wire Deformometer 3D	CRC5101003

## The Company

For over 40 years we have been producing precision and large facility monitoring instruments sold throughout the world.

Accuracy in design, efficiency in construction, reliability in management; these are the prerogatives that every major work must have and that Structural Monitoring Systems must guarantee.



### Technical assistance

If you have any requests or questions about our instruments or if you have special needs that require different solutions from the standard, please contact us. Our team will provide all the necessary information and will be very happy to work with you to study, develop and customize instruments and solutions suitable for your specific needs.

All data present in the sheets could change without notice.

Please check the release carefully and for more details contact Pizzi Instruments.

**Pizzi Instruments S.r.l.**  
Via del Fornaccio, 46  
50012 - Vallina - FI - Italia

Phone/Fax : +39 055 6810722  
info@pizzi-instruments.it  
www.pizzi-instruments.it

