



LEA_IT_PND1001000



Direct and Inverted Pendulum

www.pizzi-instruments.it
Instruments and Systems for Geotechnical and Structural Monitoring

LEA_IT_PND1001000

Direct and Inverted Pendulum



Description

Direct and inverted pendulums are generally used to measure rotations and translations of large structures such as concrete dams, tall buildings, towers and steeples, etc. The direct pendulum is generally used to measure the rotation of a structure, while the inverted pendulum is used to detect horizontal movements (translation) of a structure with respect to deep points in the foundation rock. Measuring systems with straight plumb lines provide relative displacements between points initially aligned along a vertical line and are particularly indicated for the measuring of rotations and deformations of very high structures.

Inverted pendulum also allows the measurement of displacements of a structure with respect to vertical alignment to a fixed point in the foundation. Used appropriately, they can also be used for the monitoring of structural rotation.

Measurement with pendulums or plumb wires, allows great precision in the measurement of essential parameters for large structures.

Various models of coordinometer for measuring the movement of the wire, manual or automatic, optical or tracking, complete the family – , Automatic models are available in tracking, laser and image processing options, while among the manual models optical and electro-optical digital reading are offered

Applications _____

Direct and inverted pendulums are generally used to measure horizontal movements of concrete structures such as dams, slender buildings, towers and belltowers.

They are used for measurement and monitoring in:

- **Dams**
- **Bridges**
- **Historical buildings and monuments**
- **Civil constructions**
- **Vertical supporting works**
- **Chimneys**
- **Belltowers**
- **Skyscrapers**
- **Industrial installations**

Features and benefits _____

- **High long-term repeatability**
- **Simple and reliable**
- **Quick and secure fit**
- **Measurable either manually or automatically**
- **Can be controlled remotely**
- **Simplicity of functional verification**

Measuring Principle _____

Both direct and inverted pendulum use the same principle of operation: the plumb line.

Due to the effect of the force of gravity, a wire, fixed at one end, acts as a perfect vertical reference.

Measuring consists in recording the movements of one or more points of structure, with respect to the gravitational vertical line made by a plumb line. In the case of the inverted pendulum, the wire is anchored at the base, generally at the bottom of a hole extending into the foundations and considered fixed. At the opposite end, the wire is connected to a special float, free to move in a cylindrical tank, usually filled with oil that always remains perfectly vertical position relative to the anchor point.

Due to the effect of the force of gravity, a wire, fixed at one end, acts as a perfect vertical reference. Measuring consists in recording the movements of one or more points of a structure, with respect to the gravitational vertical line made by the plumb line. In the case of the inverted pendulum, the wire is anchored at the base, generally at the bottom of a hole in the foundation, considered fixed. At its opposite end, the wire is connected to a special float, free to move in a cylindrical tank usually filled with oil which maintains the float in a perfect vertical position relative to the anchor point.

The **straight pendulum** is constituted of:

- **Upper system of wire fixing**
- **Guide plate for the correct positioning of the wire**
- **Lower system of wire fixing with weight**
- **Cylindrical tank and damper**

The upper fastening system of the wire is achieved by a winch, complete with tensioning roller, on which the wire is wound on for few laps and then blocked by friction, without affecting the integrity and resistance with forces or restrictions on the section.

The wire's upper fastening system consists of a winch, complete with tensioning roller, round which the wire is wound a few times and then blocked by friction, without affecting integrity or resistance by using force or restriction on the section.

The winch allows retrieval of the spare wire; necessary for extension due to tensioning of the plumb line.

The wire guide plate is installed under the winch. The wire will achieve its hinge point on a notch formed on one end of the plate. The pendulum's hinge point is on a notch at one end of the plate .

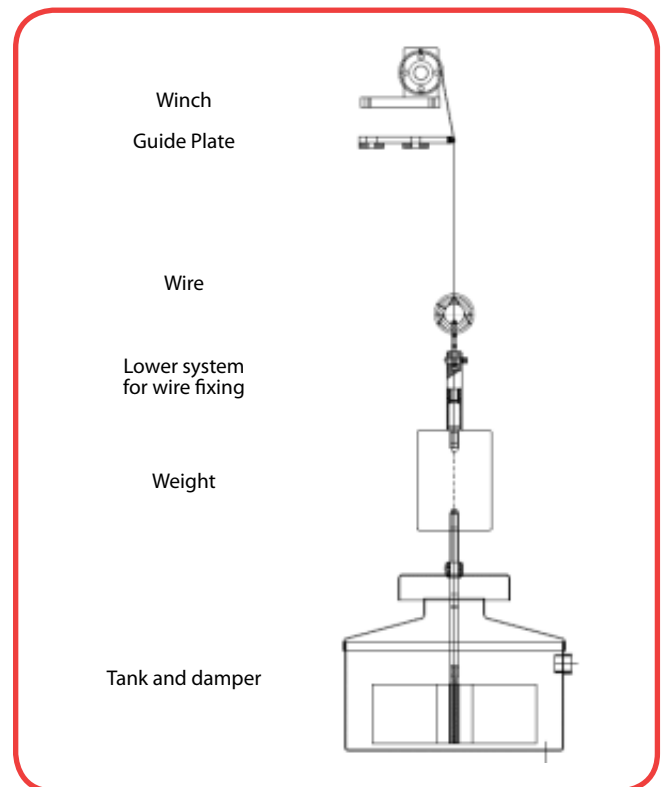

The **inverted pendulum** consists of:

- **Anchor weight with lower wire hooking system**
- **loaf with bar and stabilization weight**
- **Cylindrical stainless steel suspension tank**

The pendulum wire is fixed at its lower end to a ring, designed to prevent the formation of nicks which would decrease the resistance to traction .

Attached to the ring there is a weight that has the function to allow the descent of the wire in the hole, up to the anchor point; the whole system is blocked with a cement jet..

A weight attached to the ring, allows the wire to descend into the hole to the anchor point; the whole system is then fixed in place with cement.

At the top, the wire is hooked, using a similar ring system as above, to a threaded bar, which at its other end is engaged in the mechanical unit of the float, which has the function of stabilizing and regulating wire tension.

The suspension tank is fixed to the structure to be monitored.

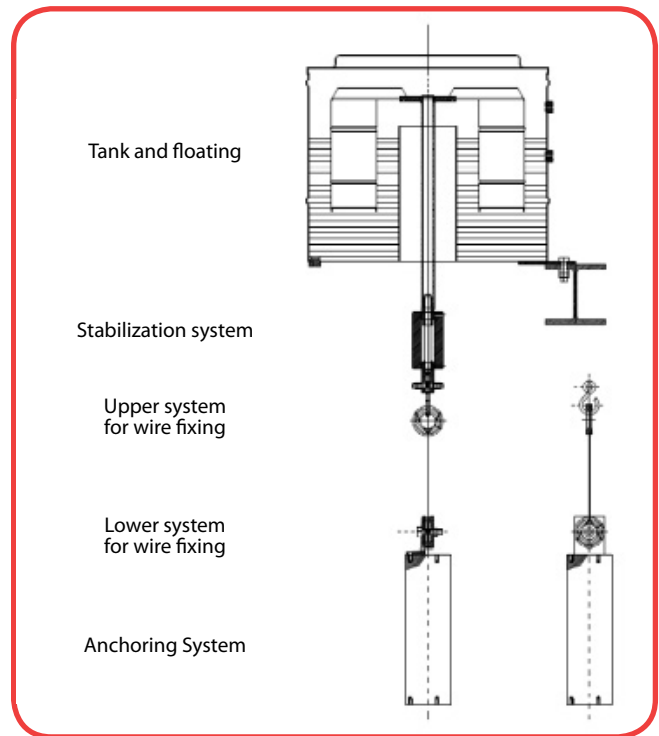

The measuring of the movements of the two pendulums, that is of the wire part of the pendulum, can be performed manually with portable removable coordinometer EGS model, or automatically using the different automatic coordinometers produced by us.

The possibility to take both automatic and periodic manual measurements for the same point ensures backup measurements and independent monitoring of the

automatic system are available.

Our technicians will suggest the most suitable model of automatic coordinometer according to specific requirements, site characteristics and monitoring system to be implemented

Pendulums of different shapes and dimension for special applications or depths, can be created by us on our clients' request.

Technical specifications

Direct Pendulum (cod. PND1101001)

Cylindrical Weight	30 Kg (optional 100 kg)
Material of the weight	Varnished iron
Suggested fluid	SAE 50-90 OIL or similar product
Dimensions of the tank	Diameter 450mm; height 220mm, with lid 305mm
Material of the tank	Stainless steel
Wire fixing	Nickel-plated brass ring

Inverted Pendulum (cod. PND1201001)

Caisson for the oil	Diameter 650, height 500mm
Material of the tank	Stainless steel
Anchoring Weight	35 kg
Material of the floating	Stainless steel
Floating strenght (standard version)	300N (Greater strenght on request)
Material of the anchoring weight	Varnished iron
Suggested fluid	SAE 50-90 Oil or similar
Wire fixing	Nickel-plated brass ring

Wire Pendulum

Material	Stainless steel
Section	1 mm (optional 1,5 mm)

Accessories and related products

Digital IP Telependulum - Image Processing Technology

Digital Automatic Coordinometer with Image Processing Technology, web server integrated, for the automatic readings of direct and inverted pendulum, readings storage, data transmission, functions of local "alarming", no movable parts

EGS – Portable Electronic Telependulum

Portable Telependulum for manual readings of direct and inverted pendulum

Electromagnetic Telependulum

Automatic Coordinometer with electro-magnetic technology for automatic readings of direct and inverted telependulum

Laser Telependulum

Laser Telependulum for the automatic readings fo direct and inverted telependulum, no movable parts

Technical assistance _____

If you have any requests or questions about our instruments or if you have special needs that require different solutions from the standard, please contact us. Our team will provide all the necessary information and will be very happy to work with you to study, develop and customize instruments and solutions suitable for your specific needs.

LEA_IT_PND1001000

Direct and Inverted Pendulum

The product information may be subject to variations at any time.
Please carefully check the release and contact Pizzi Instruments for further details.

Pizzi Instruments S.r.l.
Via del Fornaccio, 46
50012- Bagno a Ripoli (FI) - Italy

Tel: +39 055 6810722 - Fax: +39 055 6584923
info@pizzi-instruments.it
www.pizzi-instruments.it

