



LEA_IT_TLT3001001



High precision Electrolevel Tiltmeter

www.pizzi-instruments.it
Instruments and Systems for Geotechnical and Structural Monitoring

LEA_IT_TLT3001001

High precision Electrolevel Tiltmeter

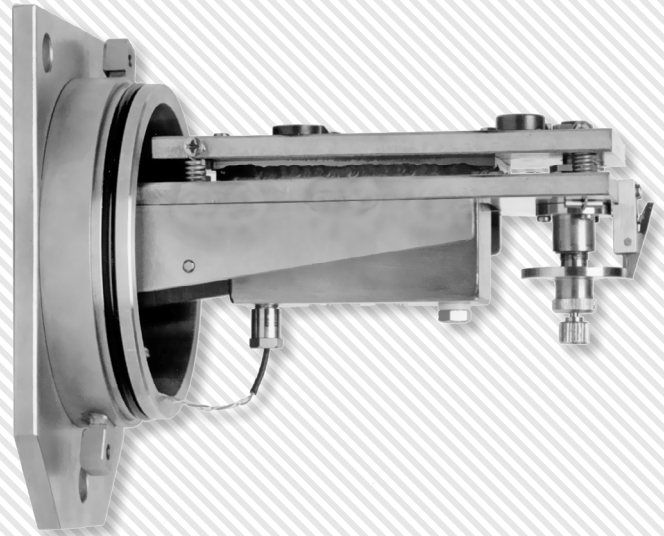

Description

Our electrolevel tiltmeter TILT 2000 measures small rotations with high precision, using a high sensitivity electronic level as a sensor. The instrument has its own specially designed base which allows the verification and eventual correction of drifts.

The instrument was designed and produced to the requirements of our client: the quality of the sensor and the

accuracy of the mechanical system of movement make the instrument unique able to provide the highest quality data. The 4-20mA output allows the reading of the instrument by the most common dataloggers and portable units on the market in addition to those produced by Pizzi Instruments.

Applications

The instrument has been specifically designed as a substitute for the pendulum or to be additional to it, where the use of pendulums is not possible, either due to cost or due to suitability of the structure. The tiltmeter is a viable alternative, both from a technical and economic point of view.

The instrument is also used for measuring deformation in very tall and slender structures.

Among its multiple applications are:

- Dams
- Bridges
- Viaducts
- Minarets
- Towers
- Chimneys
- Skyscrapers
- Walls
- Other

Features and benefits

The tiltmeter TILT2000 was designed and built to pass a series of functional tests in particular regarding electrical and environmental conditions; as proof, various tests were performed on a sample of instruments and briefly summarized below:

Tests in climatic chamber

The behavior of the instrument was monitored in varying temperatures and constancy of behaviour and return to initial values were tested. The following tests were performed:

1) thermal cycles in climatic chamber as required by standard CEI 50-3

2) change in temperature and humidity cycle (not referable to normalized cycles). In both cases, measurements at the beginning and at the end of the cycles were taken, taking as reference measurements made with our bubble level clinometer (range 60', precision 2").

The instruments showed constant behavior and an excellent return to initial values at the end of the cycle; there is still however the need during the installation phase, to make provision to protect the group with insulation and

to take appropriate precautions to minimize the effect of temperature during normal monitoring.

Fatigue test

We checked the behavior of the instrument when subjected to fatigue testing through sinusoidal vibrations.

The tests were performed according to CEI 50-6, test Fe.

The fatigue tests were carried out in 20 sinusoidal vibrations cycles in two directions (vertical and horizontal in the direction of measurement), in scanning 2-100 Hz, with severity:

- **0.75mm peak amplitude in the 2-9Hz range**
- **0.2g (1.96 m / sq) of peak acceleration in 9-100Hz range**

For tests of insensitivity to vibrations, we carried out two readings for each examined frequency: 1, 2, 5, 10, 55 Hz, for the vertical direction; 0.5, 1, 2, 5, 10, 20, 30, 55 Hz, for the horizontal direction. This with the above severity.

During tests, the average values experienced deviations generally lower than 1% F.S. with the exception of tests at 10 Hz where more significant changes to measurements were detected (10%).

There was no evidence of loosening of the instrument or mechanical damage at the end of the fatigue tests.

Electromagnetic compatibility tests (ref. ENEL GLI-EMC) insulation Impulse (GLI 01)

- Severity level: 3
- Common mode application: Outcome OK
- Differential mode application: Outcome OK

(The impulse is cutoff due to the presence of transient suppressors mounted between the two test circuit terminals)

The test was performed in common mode excluding the protective devices.

Immunity to transients with high energy content (GLI 08)

- Level of severity: 3

Test performed with output signal of about 12 mA (equivalent to a 0° inclination)

- Common mode application: Outcome OK
- Differential mode application: Outcome OK

Transient immunity muted with f = 0.1MHz and F = 1MHz (GLI 0.4)

- Severity level: 3

Test performed with output signal of approximately 12mA (equal to a 0° inclination) (common mode) to f = 0.1MHz: Outcome OK

- Power circuit: Outcome OK
- Signal circuit: slight influence; e%=1.56

Differential mode f = 0.1MHz: Outcome OK

- Power circuit: Outcome OK
- Signal circuit: Outcome OK

Common mode to f = 1MHz: Outcome OK

- Power circuit: Outcome OK
- Signal circuit: slight influence; e%=0.69

Differential mode to f = 1MHz: Outcome OK

- Power circuit: Outcome OK
- Signal circuit: slight influence; e%= 0.25%

Immunity to series of sinusoidal waves in low voltage with f = 0.01 to 1 MHz (0.6 GLI)

- Severity level 3

Test performed with output signal of approximately 12mA (equal to a 0° inclination).

- Power circuit: Outcome OK
- Signal circuit: Outcome OK

During the preliminary test in variable frequency, there were slight variations of signal frequency around 70kHz and 450kHz.

Note

The slight variations occurring, during the application of the disturbance were such that the signal variation does not trigger alerts and/or alarms.

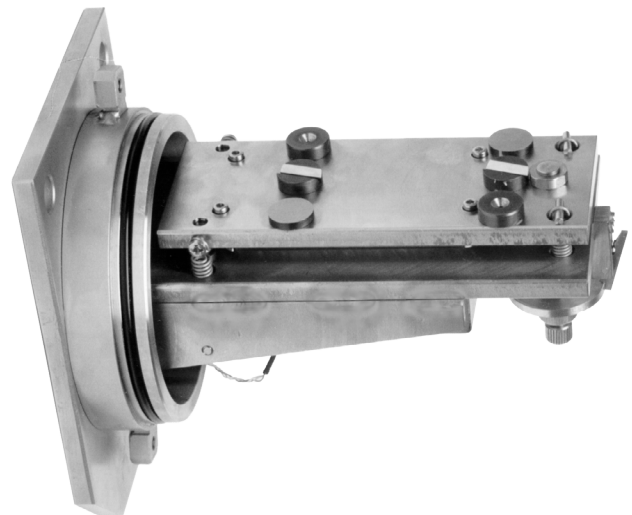

Measurement principle

The sensor behaves pretty much like a potentiometer; since resistance is realized by a liquid electrolyte, sensor requires power in AC. The supply voltage normally used varies from 0.5V to 5V, with a frequency range from 20 Hz to 20,000Hz.

The instrument is provided with a specific signal conditioner for the DC power supply and for adjusting the signal; the average life is estimated at 400.000 hours.

The sensor is supported by a suitable base which also monitors and calibrates the sensor, thanks to a device specifically designed and made by us with high quality precision mechanics.

The base which supports the sensor can perform small rotations, operated manually, by a mechanical device fixed to it. On the same base, there are three special feet that support a high accuracy bubble level clinometer (accuracy 2" on a range of $\pm 30'$).

When the horizontal clinometer sensor is placed on the base, a measurement can be taken using either the automatic sensor or the manual clinometer; the high accuracy of the latter instrument allows verification of the zero value of the sensor (as measured at the time of installation).

When the base is rotated, it measures the extent of the tilt both with the bubble level clinometer and with the electrolytic sensor. The eventual difference in the measurements gives us the parameters for the correction of instrumental drift; correction which is carried out by acting on the electronic gain of the sensor conditioning.

The base's mechanical rotation device ensures the perfect repositioning of the base in its initial position (before the test). Positioning accuracy guarantees an margin of error ten times smaller than instrumental error.

This method allows the elimination of the most important causes of error in these types of instruments

Conditioner and converter guarantee:

- **Conditioner operating temperature: 25°C to + 70°C**
- **Temperature drift of the converter 4-20mA: 100ppm/°C**
- **Supply Voltage: 24Vdc-25%/+50%**

Optionally, an 3000VDC electronic buffer is available for the galvanic insulation of the supply voltage and signal circuits.

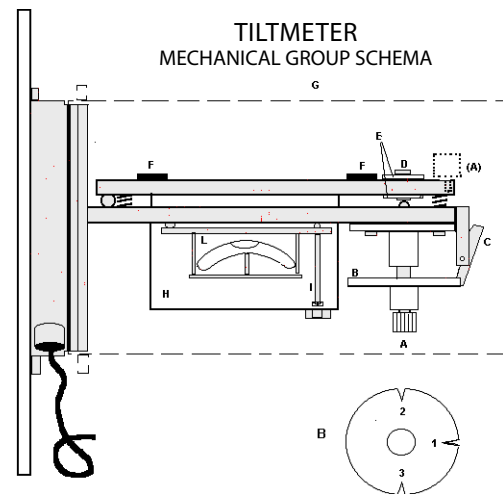

Technical assistance

If you have any requests or questions about our instruments or if you have special needs that require different solutions from the standard, please contact us. Our team will provide all the necessary information and will be very happy to work with you to study, develop and customize instruments and solutions suitable for your specific needs.

Technical Specifications

Full Range:	60'
Measurement Error:	
In range 9':	<0,15% f.s.
In range -9' ÷ -30' e +9' ÷ +30':	<4% f.s.
Maximum Absorption:	<150 mA
Converter 4-20 mA:	13 bit
Coefficient temperature zero point (null):	5"/50 °C
Coefficient temperature scale factor:	0,06% f.s./°C
Time Coefficient:	TC = 2,5 sec
Working temperature rang:	From 25 °C a +70 °C
Drifts of temperature from the converter 4-20 mA:	100 ppm/°C
Supply Voltage:	24 Vdc -25% / +50%
Optional:	Electronic Buffer 3000 Vdc for the galvanic isolation between supply voltage and signal circuitry

Accessories and related products

Junction Box	Available into different models for the connection of different instruments
Selection and Measurement Box	Complete measurement box with MUX cards for the automatic selection
Measurement Box	Simple measurement box
Cable	Multipolar Cable
DEC3000	Portable Datalogger
CUM3000	Multichannel Datalogger
MUX	Multiplexer for the connection of different sensors to the Datalogger
MUX	Multiplexer per la connessione di diversi sensori al Datalogger
Bubble Level Clinometer	For the comparison between the electric measurement and correction of drifts.

LEA_IT_TLT3001001

High precision Electrolevel Tiltmeter

The product information may be subject to variations at any time.
Please carefully check the release and contact Pizzi Instruments for further details.

Pizzi Instruments S.r.l.
Via di Ripoli 207/F
50126 - Florence - Italy

Tel/Fax: +39 055 6810722
info@pizzi-instruments.it
www.pizzi-instruments.it

