



LEA_IT_TLT1001001



Bubble Level Tiltmeter

www.pizzi-instruments.it
Instruments and Systems for Geotechnical and Structural Monitoring

LEA_IT_TLT1001001

Bubble Level Tiltmeter



Description

The bubble level tiltmeter is used in structural monitoring to detect, with high accuracy, small rotations or small variations of inclination in the structures where it is used. The instrument is manual, removable and completely optical/mechanical and guarantees very high precision, difficult to achieve with other instruments.

Thanks to a specific design (created by Officine Galileo Spa) and precision manufacture using highest quality materials, this instrument guarantees measurements to an accuracy

of 2 "sexagesimal on a range of $\pm 30'$

Used with appropriate bases, it can take direct and combined measurements, allowing the elimination of systematic errors; which is further proof of the instrument's validity.

Due to the ease of installation and taking readings, it is used in buildings, dams, large structures, historical works and all other range where very high accuracy and minimum invasiveness of installation is required.

Applications

Excellent professional instrument to measure the rotation and deformation in structures of all types; including in particular:

- Dams
- Tunnels
- Bridges
- Viaducts
- Civil buildings and historic landmarks
- Monuments
- Archaeological sites
- Diaphragm walls and walls
- Piles
- Towers
- Chimneys
- Minarets
- Various

Features and benefits

The instrument has:

- High accuracy
- Precision machining
- High quality optic group
- Possibility of Systematic error compensation
- Easily transportable
- Robust
- Easy to use
- Great for high quality professional services

Measurement principle —

The bubble level tiltmeter gets its name from the very sensitive level located within it and whose rotations are controlled by a mechanical amplification system with levers and micrometer screw. The rotation hinges are made from rectified knife-edges.



All moving parts, micrometer screw, knife-edges, and levers, are made of finely treated and rectified steel. The main components, in particular the support plates, are stabilized with repeated thermal cycles; this ensures exceptional stability over time, and also avoids minimum settling of materials. The instrument thus demonstrates high stability with regards to temperature.

Observation of the bubble is by an optical prism system, which places the images from the two ends of the bubble side by side and compares them regarding centering.

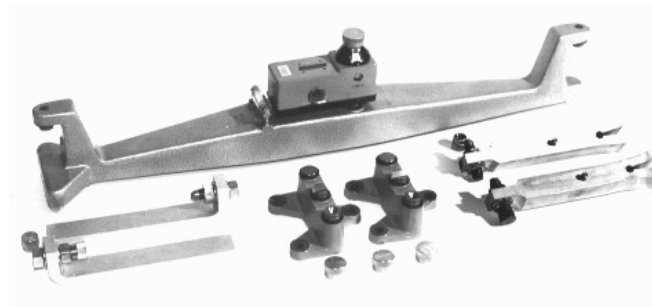

This system ensures high precision and constancy of readings; it is possible to detect bubble displacements of up to 0.2 mm. A moveable mirror makes viewing from different directions easy.

The command button has graduations corresponding to 2" of change in angle of the level. One turn of the dial is 2".

A second dial gives a reading of the minutes (60').

The total measurement range is 1°. Achievable accuracy is 2" direct, 1" estimate. The graduations of the instrument can be observed on two sides at 90°; this is a distinct advantage, as it makes observations possible even in installations with limited space. There are two windows, two indicators and two graduated scales (one black, one red). The bubble level clinometer can be used for spot measurements or for measurement of deformation. In the first case, circular bases are commonly used. In the second case, the clinometer is mounted on a special stainless steel extension which has a measurement base of 800 mm.

When using circular bases, the clinometer is equipped with 3 spherical feet which rest during the measuring phase on hardened and rectified steel mountings (one plane, one conical and one with trace), which allow the univocal positioning of the instrument.

The base is equipped with 4 sets of 4 mountings that make up the 4 measuring positions orthogonal to each other. It is therefore possible to measure the inclination in the two orthogonal axes and make combined readings for both directions. For measurement with the 800 mm base, two types of support are available: bases to be horizontally fixed and fixtures to be attached vertically to walls. Both types allow the creation of continuous clinometric strings for the detection of deformation.

Mountings for the extension are equipped with supporting feet similar to those of the circular bases. Both types allow the inversion of the instrument for taking combined measurements.

Square fixtures are available for installation on the ceiling. These also require an 800mm base extension and are normally used in tunnels and galleries.

Accessories such as templates for the installation of horizontal bases and fixtures, both straight and square, are available.

Clinometers with range $\pm 1^\circ$ are available on request

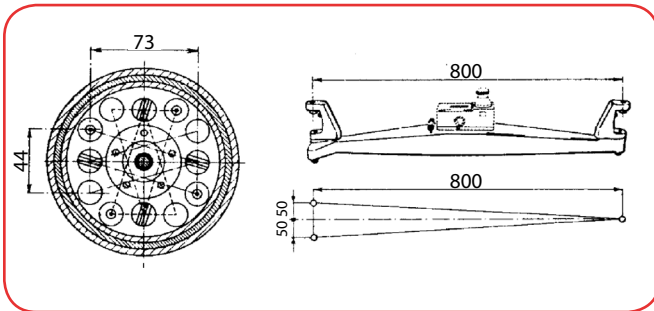

Technical specifications:

Measuring Range	±30'
Direct Accuracy	2"
Estimated Accuracy	1"
Weight	1,7Kg
Housing	AL
Dimensions of the housing	21cmx12cmx15cm
Weight of the instrument with housing	2,8Kg
Circular Base	Inox, with 4 sets of support feet
Weight of the circular base	2,2Kg

Accessories and spare parts

Stainless Steel Circular Base	For control of rotations
Stainless Steel Extension Base 800mm	For control of rotations and deformations
Pair of mountings for clinometer extension	For clinometer applications on extension on horizontal level base
Pair of fixtures (wall application) for clinometer extension	For clinometer applications on wall of the extension
Pair of fixtures (ceiling application) for clinometer extension	For clinometer applications on ceiling of the extension

Related products

MEMS Clinometer	Automatic Sensors for the measurements of rotations and inclinations
High Precision Electrolevel Tiltmeter	High Precision Automatic Instrument with the possibility of verification and correction of drifts.

Technical assistance

If you have any requests or questions about our instruments or if you have special needs that require different solutions from the standard, please contact us. Our team will provide all the necessary information and will be very happy to work with you to study, develop and customize instruments and solutions suitable for your specific needs.

LEA_IT_TLT1001001

**Bubble
Level
Tiltmeter**

The product information may be subject to variations at any time.
Please carefully check the release and contact Pizzi Instruments for further details.

Pizzi Instruments S.r.l.
Via di Ripoli 207/F
50126 - Florence - Italy

Tel/Fax: +39 055 6810722
info@pizzi-instruments.it
www.pizzi-instruments.it

